

DSP310 DSP320

PA Speaker



Description

This series of products is a multi-functional loudspeaker, available in wall-mounted and floor-mounted types. This series of products can provide high-quality voice and music reproduction functions, and relatively long sound transmission distance. It is suitable for conference rooms, shopping malls, exhibition halls and other indoor and outdoor occasions.

Features

- Suitable for public address and background music playback.
- With clear and bright sound, bringing quality sound experience.
- Using high-quality PP material for drum paper of the speaker unit, and rubber edge moisture-proof treatment, for good sound quality and timber performance.
- Simple in appearance and shape, using fine round hole diffusion design for the mesh, beautiful and durable, so that the speaker can be perfectly integrated into any occasion.
- Using high-strength ABS material for the shell, sturdy and durable.
- Equipped with mounting bracket, easy to install.

Specifications

Model	DSP310/DSP320
Speaker Unit	3"×1
Rated Power (RMS)	20W
Working Voltage	70V/100V
Sensitivity (1m, 1W)	86dB±2dB
MAX. SPL. (1m)	96dB±2dB
Frequency Response	180Hz~20kHz
Dimensions (H×W×D)	∅100×172mm
Weight	0.8kg

Product Information

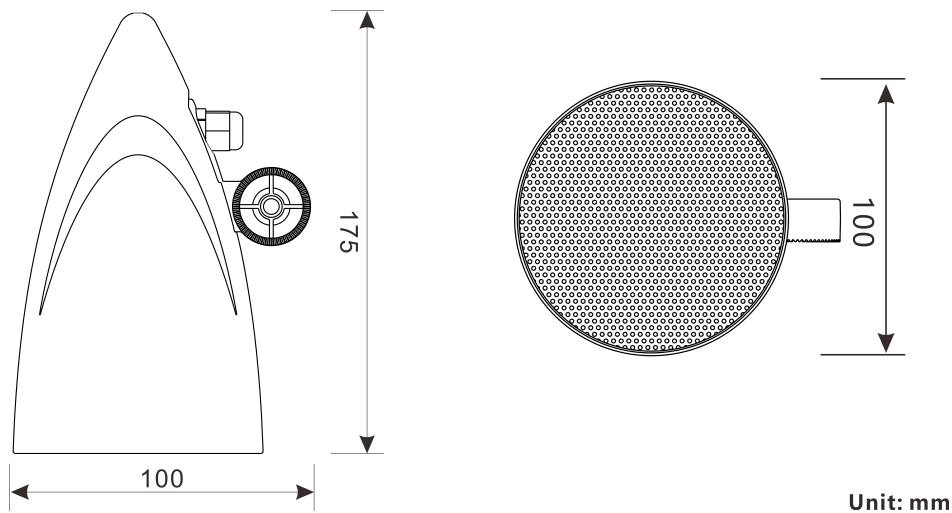

Technical Parameters

Frequency Response

(dB SPL, 1W, 1m)

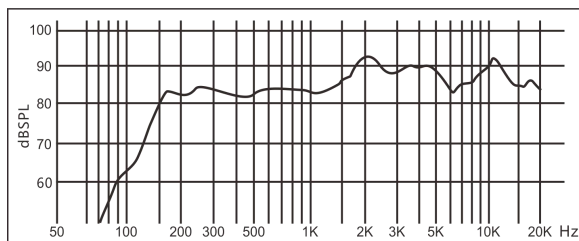

Distortion

(THD < 5% 1W, 1m, 100Hz-10kHz)

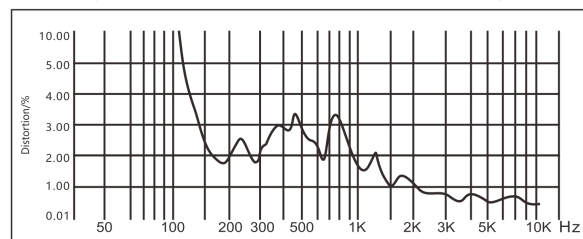

Directivity Pattern

